



Aluminum Self-closing Hinge

Interior door/Lightweight door/Aluminum door

W41K / W41M



Looking for hinge replacement?
Waterson Self-closing Hinge makes your door as good as new!

Hinge Models

Model	Full Name	Door Thickness	Mortise width on door F1 (min.)	Mortise width on frame F2 (min.)	Mortise depth E (min.)	Gap btw. Door and frame when closed
W41K	Self-closing-Aluminum Flush hinge-Non mortise	40~50 mm Retrofit	Non mortise	Non mortise	Non mortise	3.5~5 mm
	Self-closing-Aluminum Flush hinge-Mortise on frame	40~50 mm	Non mortise	38.5 mm	3.5~5 mm	< 1.5 mm
W41M~400 4*4" (H*W)	Self-closing-Aluminum Mortise hinge-4*4"	40~45 mm	33.5 mm	33.5 mm	3.3 mm	1.2~1.9 mm
W41M~450 4.5*4.5" (H*W)	Self-closing-Aluminum Mortise hinge-4.5*4.5"	45~50 mm	38.5 mm	38.5 mm		

** For non-mortise installation, preserve at least 8.5 mm gap between door and frame.

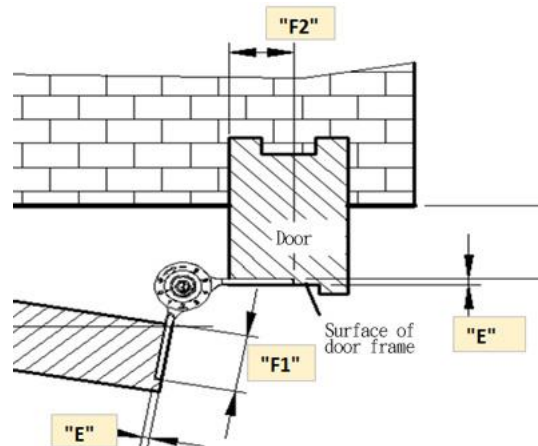



S (Spring Power)



H (Hydraulic Buffer)

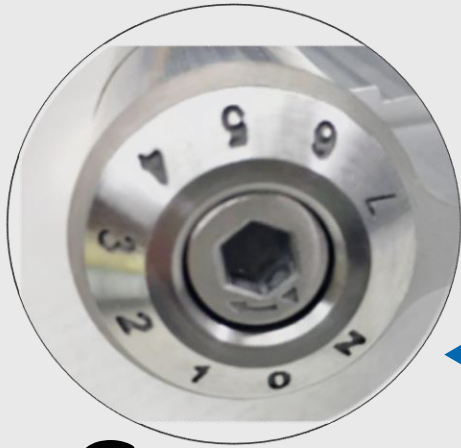

S (Spring Power)



A1.A (Mechanical Buffer)
B (Hold-Open)

Models for Waterson Aluminum Self-closing Hinge

Top	Function	Bottom	Function	Type for order	Mechanism
H	Hydraulic Buffer	S	Spring power (provide door closing power)	HS	Hydraulic Buffer + Spring power
H	Hydraulic Buffer	A	Control closing speed in 20°-90°	HA	Hydraulic Buffer + Mechanical Buffer
S	Spring power (provide door closing power)	S	Spring power (provide door closing power)	DS	Double Spring power
S	Spring power (provide door closing power)	B	Hold-open in 85°±5°	SB	Spring power + Hold-open

Hinge Combination and Position

SB (Spring & Hold open)

Hold-Open
(in $85^{\circ} \pm 5^{\circ}$)

Interior Door ≤ 70 kg
Height ≤ 2150 mm
Width ≤ 1050 mm

HS (Hydraulic & Spring)

DS (Double Spring)

Non Hold-Open

Interior Door ≤ 70 kg
Height ≤ 2150 mm
Width ≤ 1050 mm

HA (Hydraulic &
Mechanical Buffer)

Save a little room for me

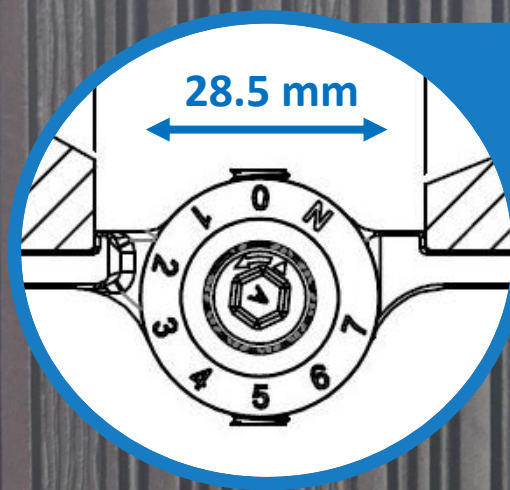

BEFORE



Also fitting for hinge replacement!



AFTER

