



# Aluminum Self-closing Hinge

Interior door/Lightweight door/Aluminum door

W41K / W41M



Looking for hinge replacement?  
Waterson Self-closing Hinge makes your door as good as new!

# Hinge models

Model	Full Name	Door Thickness	Mortise width on door <b>F1</b> (min.)	Mortise width on frame <b>F2</b> (min.)	Mortise depth <b>E</b> (min.)	Gap btw. Door and frame when closed
W41K	Self-closing-Aluminum Flush hinge-Non mortise	40~50 mm <b>Retrofit</b>	Non mortise	Non mortise	Non mortise	3.5~5 mm
	Self-closing-Aluminum Flush hinge-Mortise on frame	40~50 mm	Non mortise	38.5 mm	3.5~5 mm	< 1.5 mm
W41M~435 4*3.5" (H*W)	Self-closing-Aluminum Mortise hinge-4*3.5"	30~40 mm	26.5 mm	26.5 mm	3.3 mm	1.2~1.9 mm
W41M~400 4*4" (H*W)	Self-closing-Aluminum Mortise hinge-4*4"	40~45 mm	33.5 mm	33.5 mm		
W41M~450 4.5*4.5" (H*W)	Self-closing-Aluminum Mortise hinge-4.5*4.5"	45~50 mm	38.5 mm	38.5 mm		

\*\* For non-mortise installation, preserve at least 8.5 mm gap between door and frame.

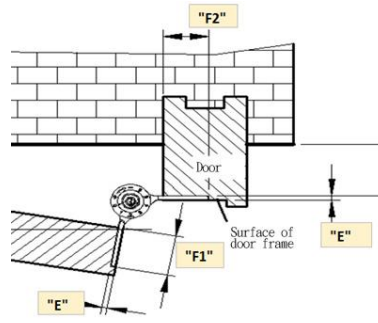



**S** (Spring Power)



**H** (Hydraulic Buffer)



**S** (Spring Power)

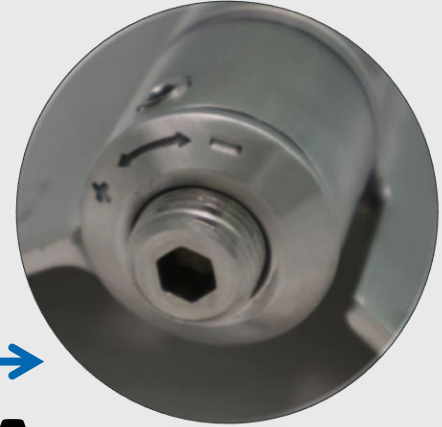

**A1.A** (Mechanical Buffer)

**B** (Hold-Open)

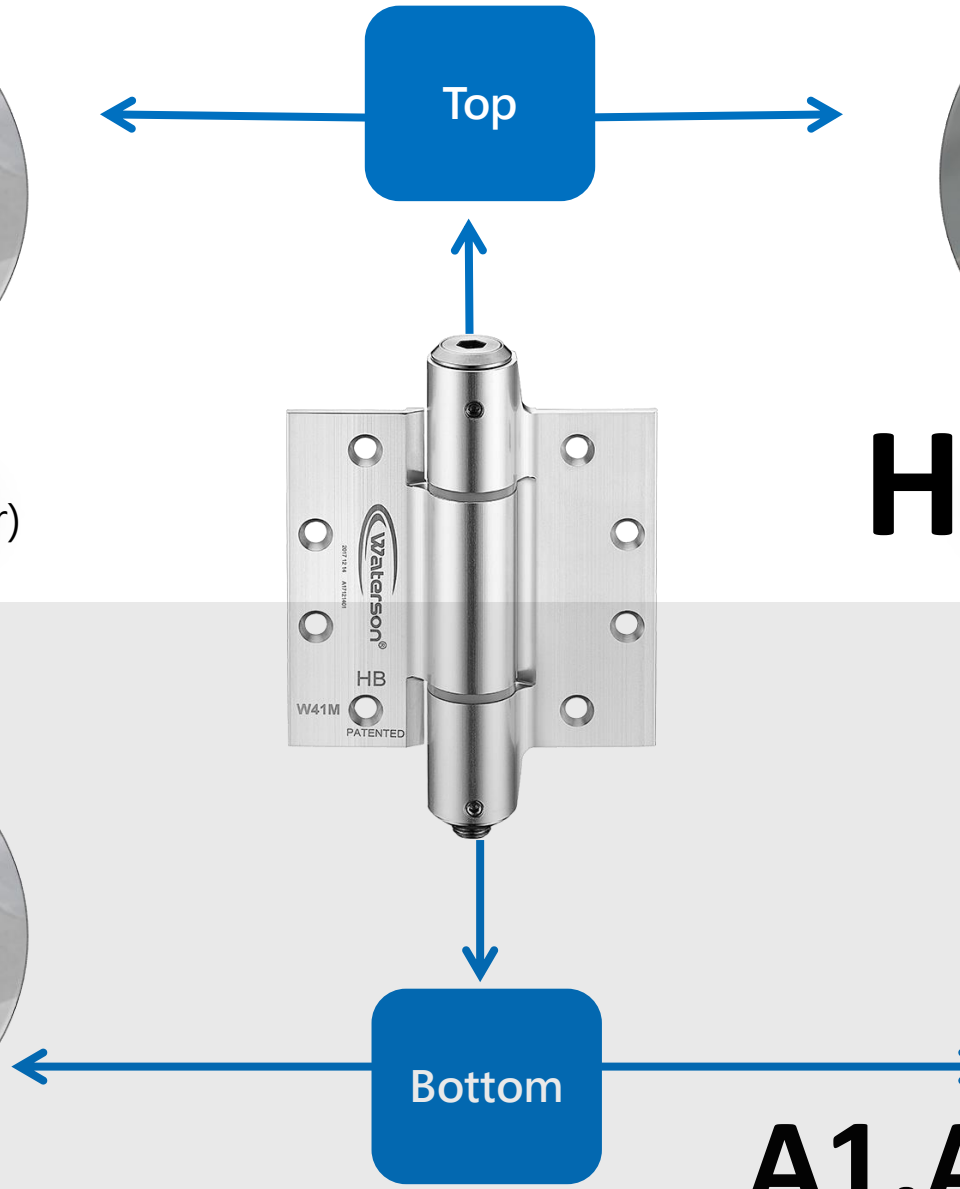

# Models for Waterson Aluminum Self-closing hinge

Top	Function	Bottom	Function	Type for order	Mechanism
<b>H</b>	Hydraulic Buffer	<b>S</b>	Spring power ( provide door closing power)	<b>HS</b>	Hydraulic Buffer + Spring power
<b>S</b>	Spring power ( provide door closing power)	<b>A</b>	Control closing speed in 20°-90°	<b>SA</b>	Spring power + Mechanical buffer
<b>S</b>	Spring power ( provide door closing power)	<b>B</b>	Hold-open in 90°±5°	<b>SB</b>	Spring power + Hold-open

# Hinge combination and positions

**HS** (Hydraulic buffer  
+Spring)

Hold open at  $85^{\circ} \pm 5^{\circ}$

For interior door  $\leq 70\text{kg}$   
Door height  $\leq 2150\text{ mm}$   
Door width  $\leq 1050\text{ mm}$

**SB** (Spring  
+Hold open)

**HS** (Hydraulic buffer  
+Spring)

Self-closing without  
hold open

For interior door  $\leq 70\text{kg}$   
Door height  $\leq 2150\text{ mm}$   
Door width  $\leq 1050\text{ mm}$

**SA** (Spring  
+Mechanical buffer)

Save a little room for me

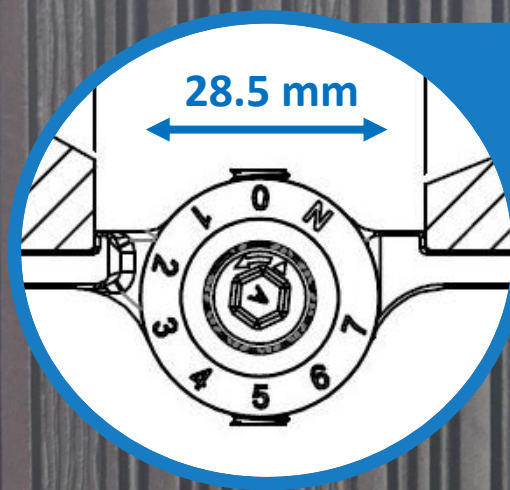

**BEFORE**



**Also fitting for hinge replacement!**



**AFTER**

